

Redwood Fences For All Reasons

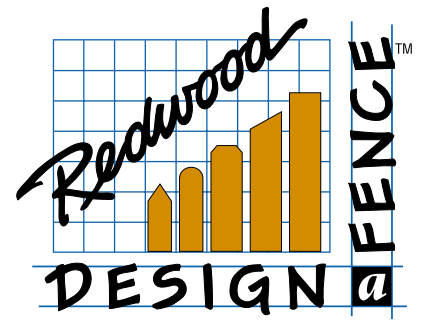

Redwood fences—capturing the great outdoors for you

There are many ways a thoughtfully designed fence can touch your life. Once you sink the posts and set hammer to nail, the results can be transformational, especially when you work with redwood—one of nature’s most beautiful, functional and enduring materials.

This booklet will stimulate your imagination by providing you with a wealth of creative redwood fence designs. You’ll also find the necessary step-by-step construction techniques for planning, designing and building your fence.

REDWOOD FENCES FOR ALL REASONS 2

Fence ideas and detail drawings

CHOOSE THE RIGHT STYLE 10

Questions and considerations

Design your fence 10

Establish layout priorities

Draw a site plan

Make a rough layout

Legal considerations

BUILD YOUR FENCE 11

Lumber grades and uses

Garden grades

Architectural grades

Posts and rails 12

Set posts

Add rails

Attach fenceboards 13

Nail-on fencing styles

Inset fencing styles

Nails and fasteners

BUILD AND HANG A GATE 15

Step-by-step construction

Hardware options

FINISHES 16



Clockwise from top: a simple inset board-and-board fence encloses a patio; 2x4 wall treatment allows filtration of light and air through to a spa and deck; craftsman style gate with an open trellis creates an inviting entrance.

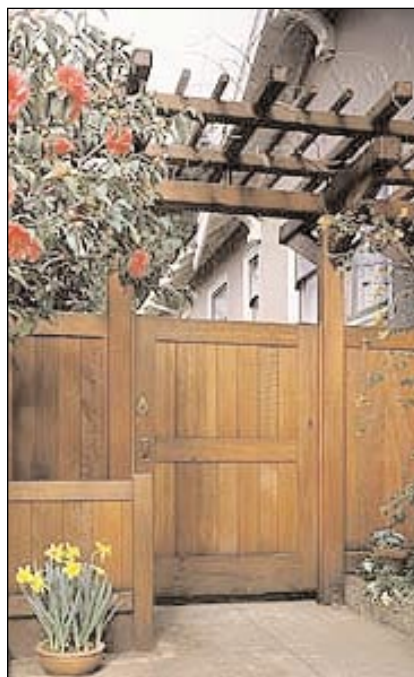

Redwood fences for all reasons

There is something deeply satisfying about a fence. Whether we're talking about a simple, rough-hewn structure that meanders around your property or an intricately designed barrier for a pool and patio, a fence adds quality to your personal spaces.

A perimeter fence is an attractive way to separate your property from the neighbors and to more fully personalize the land around your home. If there are children next door, a solid fence can help keep baseballs from rolling into your flower beds,

and it can discourage passers-by from taking an occasional shortcut across a carefully clipped lawn.

Fences are also great for those who value privacy. Cozy spaces can be fashioned for reading and relaxing that are totally sheltered from the outside world, or you can section off larger areas—even an entire yard—to form an area that is personal and protected.

Fences also define areas for specialized use, such as a pool and patio, a dog run, or an area for a private garden, while smaller sections of fences can be employed as an integral part of the property's overall landscaping design.

For the security-minded, a solid surrounding structure serves as a psychological, as well as a physical, deterrent to intruders.

Depending on where your home is located, noise and traffic from an adjacent road can be bothersome, or prevailing winds and harsh sunlight may interfere with your enjoyment of the outdoors. By softening sounds and providing a barrier to wind and sun, a fence can extend the time you spend outdoors and increase the pleasure of outdoor living. In addition, by reshaping the exterior spaces, a fence will contribute to your home's overall ambiance, appearance and value.



Window box design

This perimeter fence affords both maximum privacy and an opportunity to provide a backdrop for plantings. Though projecting a highly finished look, the fence is made from an economical grade of redwood. The Merchantable grade redwood used for the fenceboards contains a combination of heartwood and sapwood. A 2x4 intermediate rail adds design interest.

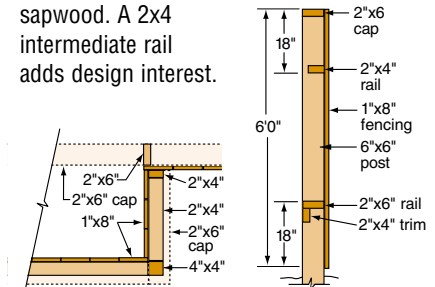

Sturdy screen divider

The screen divider has an attractively massive look with diagonal fenceboards adding a touch of lightness to the solid, box-like design. Knot-containing garden grades of redwood—Construction Heart and Construction Common—are ideal for a structure of this type. These grades provide the strength and durability redwood is known for at an economical price.

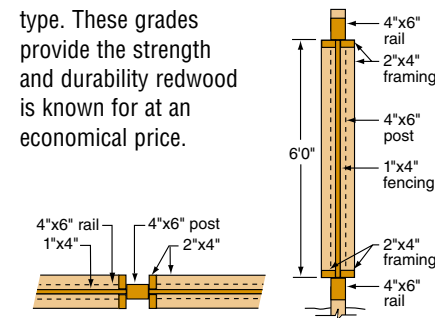

Post-board-and-rail fence

Here is an ideal design for enclosing a back yard or corner lot. The height of the fence effectively screens out street sights and sounds, and the spacing of the boards can be varied to accommodate a specified amount of air flow and privacy. Built of Clear grade redwood, the contrasting sapwood-heartwood content adds color interest to the design.

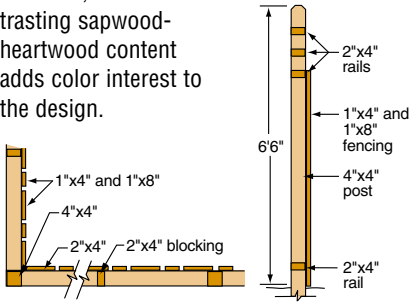

Knotty, rustic and functional

A rustic fence of Construction Heart redwood defines a property line. The fence is personalized with built-in benches and planters to add extra beauty and liveability to a house and yard. The trellis-shaded fence provides maximum privacy and protection from wind while serving as an attractive support for flowering vines.

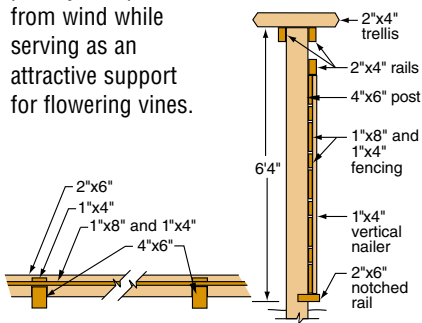

Gabled hillside fence

A series of redwood fence panels are stepped along a sloping site to create a structure of startling originality. Sections are built with Construction Heart 4x4 posts, 2x4 frames and 1x2 and 1x6 redwood fencing. Whimsical gabled redwood "roofs" alternate with sections of 1x1 upright boards.

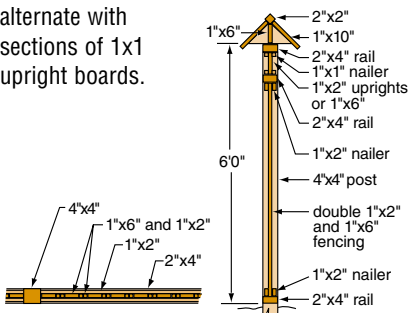



Craftsman-style fence

This fence is characterized by the use of rounded edges and custom craftsmanship. Situated along a front and side yard, the fence echoes both the Japanese character of the landscaping, and the Craftsman elements of a classic shingle house. Fence-boards are spaced apart allowing for a visual connection between the sculpted plants and the garden within.

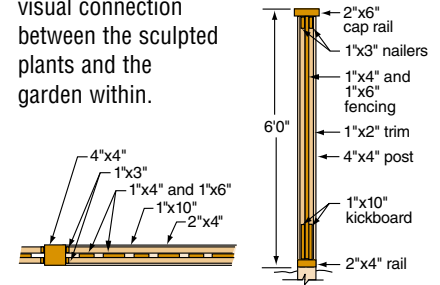

"Dog-eared" security fence

Built for a home constructed in a Victorian style, this fence of 1x8 Construction Heart redwood creates security and privacy. Alternating boards have been cut in a "dog-eared" pattern to add visual interest to an otherwise plain fence design. Security is enhanced with airy wrought iron gates. A shade trellis lends design continuity and is supported by 6x6's.

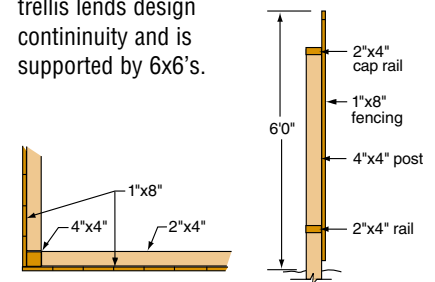

Each 8-foot module of this geometrically-shaped perimeter fence consists of 1x6's topped with five 18-inch squares crossed with 2x4's. This design adds character to the post-and-board security fence.

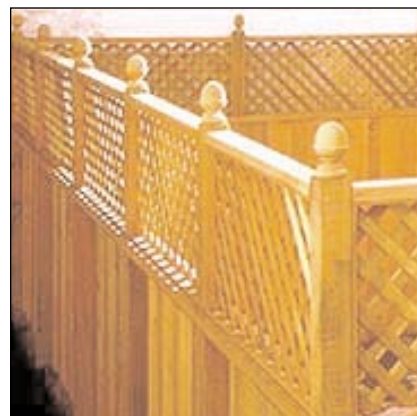

A solid board fence of Construction Heart redwood divides and makes private a commonly shared yard behind a San Francisco Victorian duplex. Lattice top and finials add old-fashioned, romantic charm.



To distinguish two separate entrances, the designer created this divider fence with lacy redwood lattice panels. Both sides present an equally finished look.

Post-and-rail boundary fence

Blending with an existing arbor, this simple post-and-rail style fence offers both security and elegance. Design details such as the kickboard and 2x6 cap rail create visual interest. Custom latticework on the gate is contained by a 2x8 intermediate rail. Fenceboards are alternating 1x4's and 1x6's with 1 inch spaces.

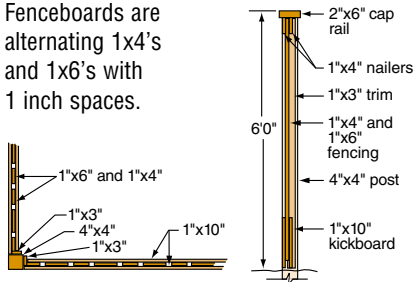

Oriental entry and fence

Posts, rails and beams of this attractive fence and pergola were constructed from Clear All Heart redwood. Fenceboards are 1x6's while the structural members and decorative elements of the pergola are fashioned from larger dimension redwood timbers. Diagonal gate boards soften the impressive entrance.

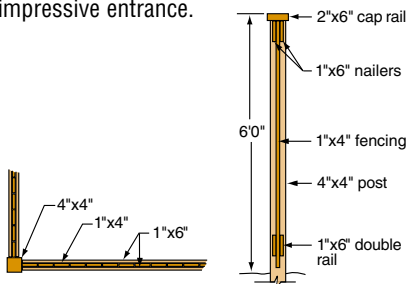

Security and privacy fence

A seven-foot-tall fence of Construction Heart redwood buffers traffic noise on a busy main street. The massive, stockade-like design is a board-on-board "good neighbor" style that looks good from either side. Supporting the 1x12 fenceboards, 2x8 top rails, kick board and cap rail are 6x8 posts. Capitals add a light touch.

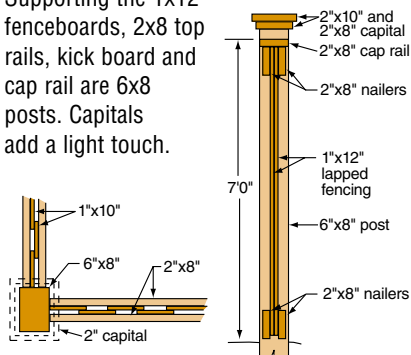



Intricate pool-side screen

Visual interest and privacy for a spa are provided by combining two different fence designs. The elegant lattice, built with 2x2's which alternate front to back, creates a decorative and airy screen, while the louvered screen provides privacy and wind protection. Overhead trellises are used to shade benches and support hanging plants,

while built-in planters complete the inviting setting.

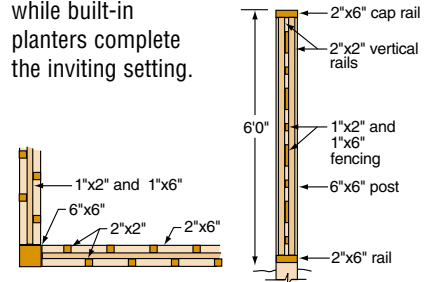

Louvered privacy screen

Louvered construction is a sophisticated way to let in light and fresh breezes while maintaining privacy. This all Construction Heart 8-foot redwood garden screen adds visual interest to the garden setting of this back yard. Louvers should always be built of dimensionally stable lumber such as redwood to prevent twisting during the weathering process.

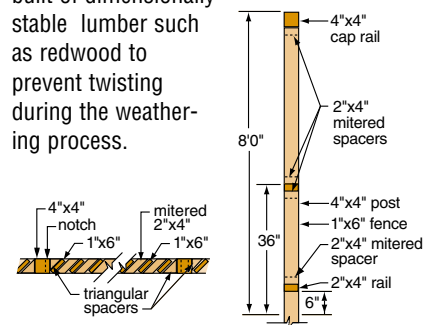

Built with Construction Heart redwood, this trellis provides shade and adds a finished look to a gated boundary fence. The garden grade redwood adds a rustic, natural feeling at an economical cost.



A painted redwood gate serves as an outdoor foyer, creating privacy and personality for the yard. The widely spaced lattice protects the yard without isolating it.



Rooftop-style canopy over a Craftsman fence shelters the entrance beneath it. Shingles on the canopy echo the design of the home. Posts are 6x6's and support the 4x4's of the canopy.

Grapestake fence

A rustic, yet contemporary six-foot-tall grapestake fence creates security and privacy in a front yard. Grapestakes are rough-cut, pointed 2x2's which vary in width, thickness and length. Support rails, top and bottom, are 2x4's. Brick columns, topped by antique-type lights, frame a 1x6 redwood gate and help to create an impressive entrance way.

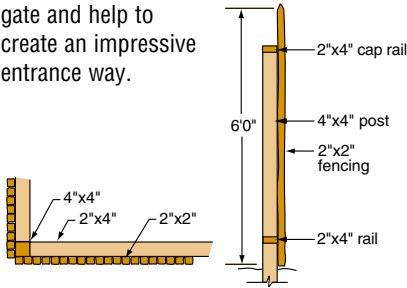

Latticework front yard fence

The latticework boundary fence was built to complement a turn-of-the-century white cottage and English garden. The 4x4 posts are shaped at the top to add architectural interest. All redwood is finished with a white solid body stain which does not peel and flake the way paints do.

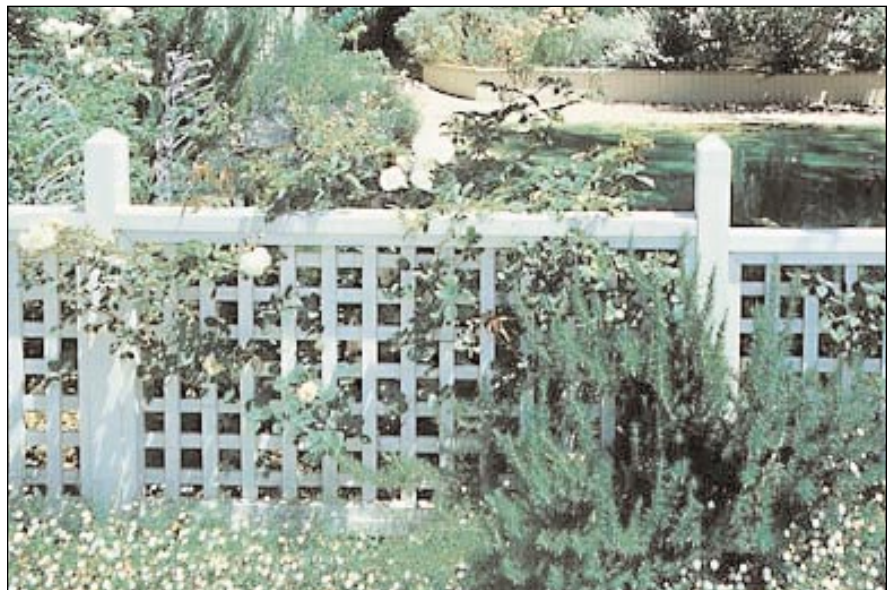
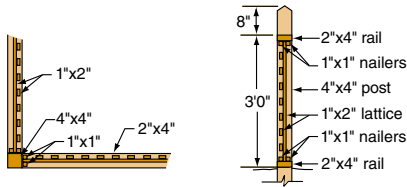

Basketweave fence

Classic six-foot-tall basketweave fence built along a side yard on a small lot creates a property line marker and provides privacy from nearby neighbors. The 3/8x8 fenceboards, specially ordered from the lumber supplier, were resawn from 1x8's. Posts are 4x6's, the inserts are 1x2's and the kickboards and rail cap are both made of 2x6's.

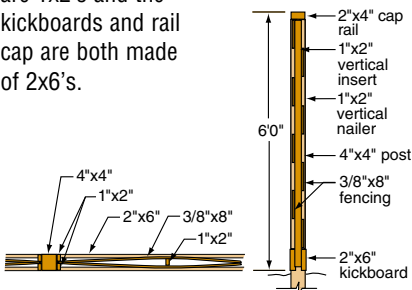



Privacy fence for spa

The Clear All Heart redwood fence allows privacy while permitting air and light to filter through to a 8-foot spa and beyond to the master bedroom. Redwood decking, planters and bench complement the 1/4x4-inch bender board fence. The 1x2 vertical nailers are attached to both sides of the fencing to provide structural stability and strength.

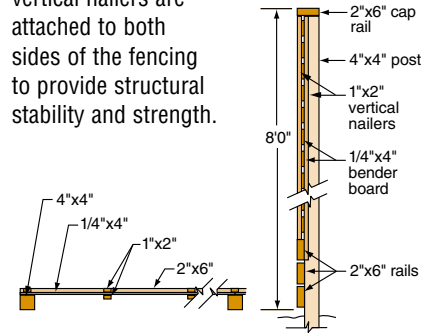

Solid wall fence

This solid perimeter fence and pergola allow privacy and protection, while the lattice fence top and gates preserve a certain airiness and light motif. The fencing, attached to both sides of the 2x4 framing, matches the 1x8 shiplap siding of the house. The palatial pergola is constructed with 6x6 posts that support 6x6's, 4x4's and 2x4's.

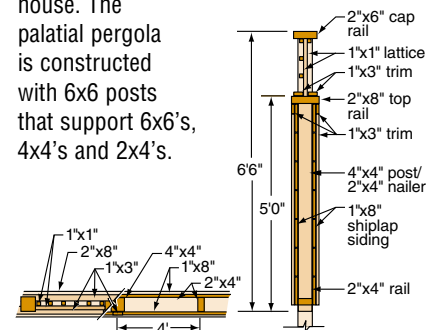

The extra deep window box acts like a greenhouse window, brightening the classic board-and-board fence. It also provides a showcase area for plants and flowers.



This redwood screen was constructed to hide a garden tool area at one end of a patio, and features custom latticework and copper inserts that have been chemically aged to a rich turquoise patina.

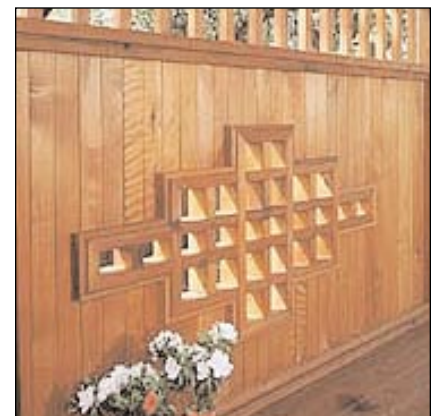

Privacy screen surrounding a built-in spa features an intricate cutout framed with a series of 2x4 boxes. Gentle breezes and filtered light keep the space from feeling dark and confined.

Gates for coming and going

A gate is often the first thing the visitor encounters, so it is worth devoting time and careful thought to the impression you want to create. For example, a brightly painted picket gate sends a welcome message to those who approach, while a tall, solid gate proclaims that only those with permission may enter. Some gates are basic and utilitarian, blending with a fence or surrounding landscapes. Others are ornamental and employ hand-forged hardware. Gates may even be framed with a canopy or arbor to create a natural and pleasing portal.

Top: This intricately crafted double gate was built using mortise and tenon construction techniques. The gate is bordered with a lacy, custom-designed, hand-forged wrought iron fence and is topped with a pleasing iron arch. Materials are Clear All Heart vertical grain redwood accented with custom, hand-forged steel gate handle and mortise lock.

Right: Upper railings of the gate are shaped in a graceful curve to match the bays of the property line fence. Fence and gate use no nails, only quality brass screws. The iron strap gate hinges and other copper and iron hardware and accents are hand-made by a local blacksmith. Alternate sizes of upright fence pickets are used to create design interest.

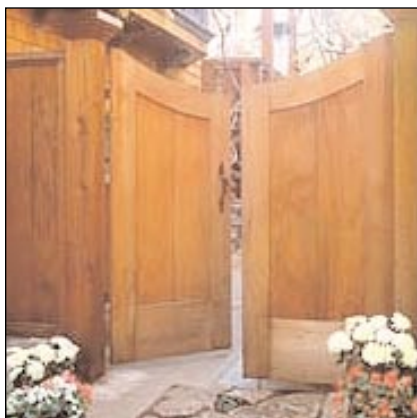

This magnificent double gate uses architectural grade Clear All Heart redwood. Supporting the weight of the gate are 6x6 posts which are topped off with capitals for a stately entrance.

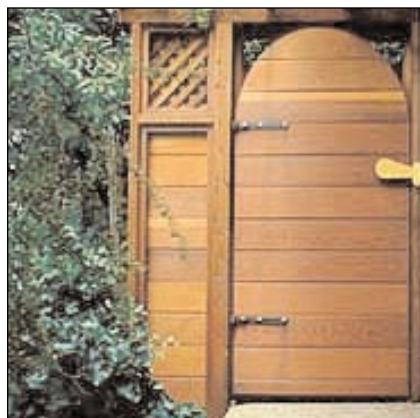

Built of Clear grade redwood, the 5-1/2 inch thick door with its graceful arch is identical on both sides. Lattice work helps to lighten the massiveness of the gate, and heavy-duty hardware supports its weight.



The designer chose smooth-textured Construction Heart redwood for this entrance to a 1930's wood-shingled house. The delicate porthole and arch add further contrast to the rough-textured fencing.

Choose the right style redwood fence

A fence is an extension of your home, and calls for as much attention to its purpose, style and design as if you were adding another room.

In your planning you need to start with specific questions. Why are you building the fence and how will it complement the character and design of your home? Are you defining a boundary? Are you looking to create more privacy or shield yourself from unwanted noise? Or is your purpose to construct a wind break, add shade to a deck or discourage the family dog from running loose in the neighborhood? Not all fences are appropriate for all purposes.

Consider, too, how your neighbors will view the fence. Some fences look wonderfully finished on your side, yet present neighbors with a less appealing view, while other designs look equally attractive from either side. A friendly chat with your neighbors can lead to a design that pleases all parties, and they may even be willing to split the cost of materials and labor.

Design your fence

There are a surprising number of fence styles to choose from, many of which are included in this booklet. There are also do-it-yourself books that contain a wealth of ideas and illustrations. Thumbing through them is a good way to get the process rolling.

You may choose to settle on an existing design, or you can create your design from scratch. You can also modify a basic design into a look distinctively yours. You'll find it fun to experiment, and even small variations will make a big difference. Keep in mind that you only need to plan the details for one typical bay (the section of fence from one post to the next). From there you can

calculate everything else you need for a fence of any length.

Remember, if you're working within a limited budget, you can still build a fence that does the job without sacrificing quality by choosing a style that uses less lumber or a more economical grade of redwood. You can also bring down costs by making the best use of standard lumber lengths.

Establish your layout priorities

A fence can impact your site in many different ways, so in your planning you need to think about which aspects of the site you want to retain and which you'd like to change. Before you finalize your fence line, carefully review your priorities to confirm that all your key considerations are being covered. Some of the questions you'll want to answer are...

- Which views do you want to keep or block?
- Which areas would you like to conceal?
- Where are the activity areas and what are the traffic patterns in those areas?
- What needs to be protected from the sun or prevailing winds?
- Is there noise you'd like to block? Where is it coming from?

- Do you want the fence to support certain vines and shrubs?
- Are there places where the fence must be in scale with existing landscaping or coordinated with existing structures like trellises and planters?

Address anything that may have a bearing on your fence layout. The more thoroughly you do this, the happier you'll be with the finished product.

Draw a site plan

You'll find it easier and less costly to resolve all your key issues while you're still at the conceptual stage. But to do this, you'll need to have a site plan. You can draw a site plan in an hour or two, or you can look for a copy of an existing plan with the building department, designer or architect, building contractor, landscape contractor or even a previous owner. Once you have a plan of your property, you can experiment with different fence line schemes.

Start by making a rough sketch of the site, including such things as site perimeter, the houseplan, driveway, patios, walkways, garden beds and utilities. You will also want to indicate grade, sun and wind orientation, and the characteristics of surrounding structures and

Fig. 1: SITE PLAN AND ROUGH LAYOUT

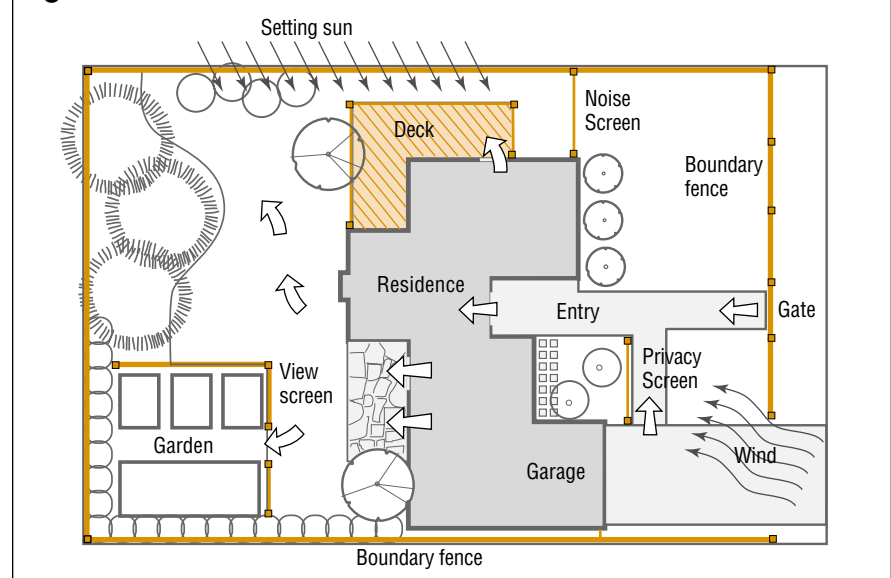

plantings. In plotting out the sun's path, visit the site several times during the day to note how shadows fall. And don't forget that the sun follows a different path in the summer than it does during the other seasons. Use circles for activity areas, arrows for traffic paths, wavy lines for winds, a yellow dotted line for sun path, squiggly arrows for noise direction, different color arrows for good and poor views...or whatever other symbols you find most practical.

Now walk the property with a 50- or 100-foot tape and someone to hold the other end. Precision counts. Take actual field measurements and note them on your sketch.

Once you're done, transfer your field measurements to 1/4-inch scale graph paper. Use light pencil lines initially to plan your fence line and only darken them when everything is worked out to your satisfaction. Also, it's a good idea to jot down the dimension next to each line. Later on, it will be easier to read than counting squares.

Make a rough layout

Once you have everything indicated, it's time to start looking at fence lines. Since you're just playing with ideas at this point, don't overwork any one layout scheme. Use tissue overlays to make various rough fencing schemes (Fig. 1).

A good rule of thumb is to keep spaces as large as possible. Most people enjoy the expansiveness of the great outdoors, so think twice before you plot a fence line that boxes people in.

If you have gates, don't forget to allow enough room for openings. Three foot openings are generally enough to accommodate one person or a large piece of equipment. Four feet will accommodate two people, while 6 feet is generally sufficient for a group. For vehicles, you want to allow a minimum of 10 feet.

Once you're satisfied that you have what you want, trace your rough layout and site plan on another tissue overlay. Indicate where the openings will be, and if there's a gate, the direction in which it will swing. Completing this step will help you calculate how much lumber will be needed to build your fence.

If you see ways to improve your fence line, don't be reluctant to make new sketches until you feel you've gotten everything just right.

Legal considerations

It's a good practice to check out the legal considerations associated with building a fence, because local codes and ordinances can vary considerably from one community to the next. Most communities have height restrictions on boundary or division fencing. There also may be certain laws and codes that actually *require* you to erect a fence, for instance, around a swimming pool or open well.

If there are any questions about on whose land the fence is being built, arrange for a survey. Remember, if any part of the fence encroaches on your neighbor's property, you may be asked to move it.

Build your fence

At this point you're ready to roll up your sleeves and get to work. Fence building is divided into three stages. First, you physically plot the fence by staking out the location of the posts, then you install the posts and finally, you add the rails and fenceboards.

Most people prefer to set all the posts in place and then attach the rails and fencing, especially when posts are being set in concrete. Another approach, however, is to assemble the fence in sections by filling in the rails and fenceboards whenever two posts are in place. This has certain advantages when you're working with prefabricated fences, or when you first build each section on the ground and then lift it into place.

Lumber grades and uses

No matter which approach you follow, you need to start by deciding what grades of redwood you wish to work with. To calculate your costs and materials, it is easiest to determine first what it will take to build one fence bay (usually 8 feet from post to post) and then to multiply that by the number of bays required to complete your fence. It is also best to add another 8% to your order so you don't run out of materials. Most fences use 4x4 posts and 2x4 rails, with the boards attached to the rails. You can choose between *garden grades* of redwood which are rugged, hard-working and economical and *architectural grades* which are preferred for fences or screens that have a more decorative or architectural function. (Fig. 2).

Garden grades

Construction Heart contains knots of a limited size and is recommended for work on or near the ground and for posts, rails, kickboards and fenceboards. As with all heartwood grades, it is decay and termite resistant.

Fig. 2: LUMBER GRADES AND CHARACTERISTICS

		Heartwood	Sapwood
Architectural Grades	Clear Limited Knots	Clear All Heart B Heart	Clear B Grade
Garden Grades	Knotty	Construction Heart Deck Heart Merchantable Heart	Construction Common Deck Common Merchantable

Construction Common is similar to Construction Heart except that it contains sapwood, which can be visually dramatic on large fences. It is recommended for most above-ground applications such as fenceboards, trellises or gates.

Deck Heart and **Deck Common** are similar in appearance to Construction Heart and Construction Common but are graded specifically for strength. Deck Heart and Deck Common are available in 2x4 and 2x6 dimensions. In addition to use as fenceboards, these grades are excellent for deck rails and caps.

Merchantable Heart allows larger knots and knotholes and is good for fenceboards, posts and rails in low fence projects.

Merchantable allows larger knots and knotholes and can be cut economically for rough or rustic fenceboards.

Architectural grades

Clear All Heart has no knots on the best face and permits small tight knots on the reverse face of occasional pieces. Because it resists decay and termites, you can use it on or near the ground.

Clear, essentially knot-free, is useful for fine architectural fence panel designs away from ground contact.

B Heart allows limited knots and is 100% heartwood.

B Grade has limited knots, contains sapwood and is used for above-ground applications.

Whether you choose garden or architectural grades, you'll find that a fence constructed of redwood will resist shrinking, warping and checking and not only age beautifully but often look better ten, fifteen and even twenty years after construction.

Posts and rails

The first step in building your fence is to locate the exact course it will take and mark the line with stakes and string. This is the most exacting part of the project, because it establishes the foundation and framework for your fence.

Fig. 3: STRING LAYOUT AND TEST FOR RIGHT ANGLES

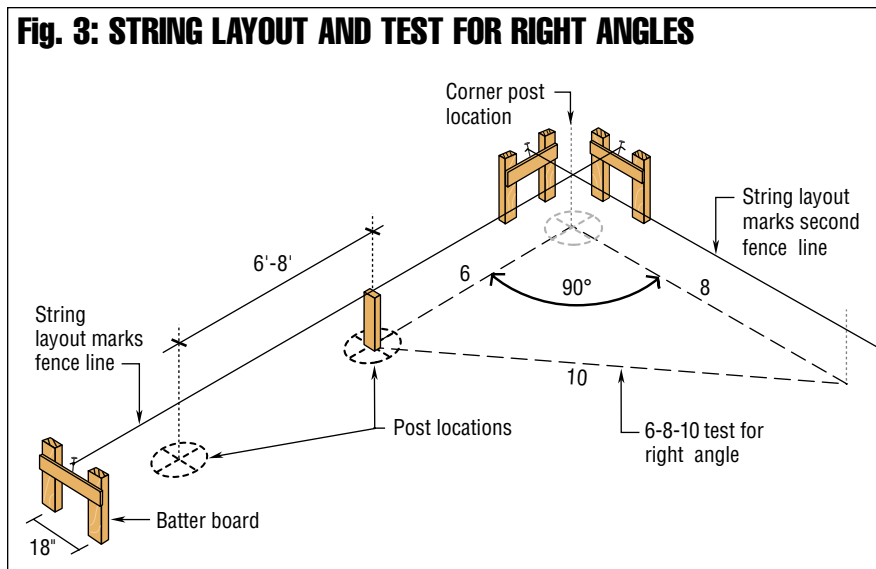

To plot a straight line for your fence, mark the location for each end or corner post with a batter board—two solidly driven stakes 18 inches apart and connected by a 1x3. Use the center of the batter board as your point of alignment and drive a nail or cut a notch. Tie a piece of mason's twine or string to the nail of one batter board, draw it taut, and tie it to the nail on the other. If the fence line is particularly long, you'll want to support the twine with stakes whenever the twine begins to sag.

Posts are generally spaced 6 to 8 feet apart, depending on the style of fence. Measure and mark the center locations of all the posts with chalk or a pen. Corner posts will be located directly under the crossing stringlines at the batter boards. Take the string of your plumb line, line it up directly with the first chalk mark. Mark where the point of the plumb bob falls, using a spot of spray paint or a stake stuck into the ground. Paper nailed into the ground can also serve as a marker. Once the center marks for all the posts are indicated, you can untie the string.

If your fence includes 90° right angles, they can be accurately determined by using the 6-8-10 triangle measuring technique shown in Fig. 3. Any multiple of 3-4-5 will work, although larger numbers are easier to measure.

Establish the first fence line as explained above. Then establish the second fence line roughly perpendicular to the first, using another batter board. Measuring from the stake that will form the corner, place a chalk mark 6 feet away along the twine that forms the first fence line.

Next, put a mark 8 feet away from the corner stake on the twine forming the second fence line.

Finally, measure the distance between the two chalk marks and adjust the second fence line on the batter board until the diagonal measurement between the two marks equals 10 feet. This gives you an accurate 90° angle.

Set posts

Now comes the hardest part of building a fence: digging the holes and setting the posts. For the first

FIG. 4: POSTHOLE DIGGER

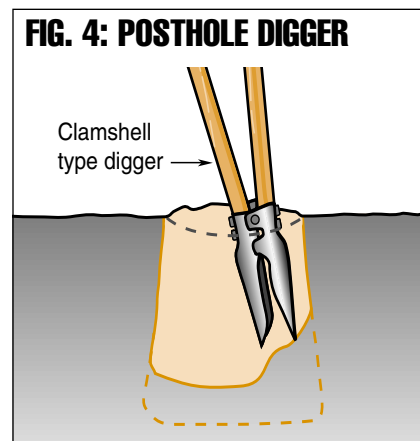
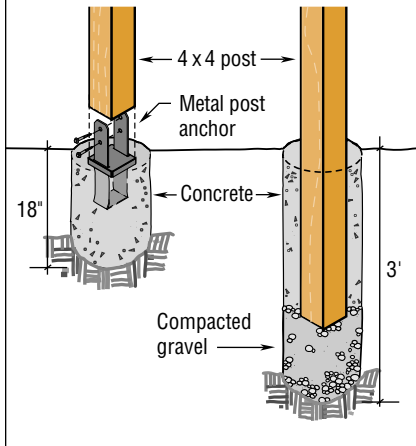

Fig. 5: POSTHOLE OPTIONS



step, a post-hole digger is often all you need, but if there are many holes to dig, you may want to consider one-man or two-man power augers. Augur-type diggers are good for rock-free earth, but if you're likely to encounter large stones, a clamshell type is better (Fig. 4). A digging bar is also useful for prying rocks and other hard-to-move debris from the hole.

In most cases, your posts will be 4x4's or 6x6's, depending on fence style. Posts can be set directly into the concrete or attached with metal post anchors. Posthole diameter should be at least 3 times the width of the post. Post depth should be 1/3 the *above-ground* height plus an additional 6 inches for the rock or gravel bed (Fig. 5). If you experience frost where you live, dig post-holes down to a foot below the normal frost line to minimize damage from ground shift due to alternate freezing and thawing of soil.

Once the holes are dug and all loose dirt is removed, make a drain bed at the bottom of each hole by shoveling in about 6 inches of gravel. Working carefully, set the posts, making sure that each one is plumb and kept from moving with braces staked to the ground (Fig. 6). To make sure all the posts are in alignment, reattach the twine to the batter boards and move the tie points so that the twine runs along the outside of the posts.

You will also want to adjust posts for height at this time by anchoring a string on top of one post, drawing it taut and anchoring it to the top of the next. Then, running a level along the string, move the second post until it's in alignment.

When pouring concrete post footings, make the concrete thick enough so that you can solidly pack it into the hole. Ready-mixed concrete is preferable for most applications; however, if you elect to mix your own, use a mixture of 2 parts cement, 3 parts sand and 5 parts gravel. Allow the concrete to set for at least 2 days before you begin attaching the rails.

Add rails

Once the posts are set, the hardest part is over, and it's time to start giving form to your fence by adding the rails. Start by marking and cutting the top rails so that they will span from one post to the next of each 6 or 8 foot bay, then nail them in place. Once the top of the frame is tied together, go back and

Fig. 6: SET POSTS

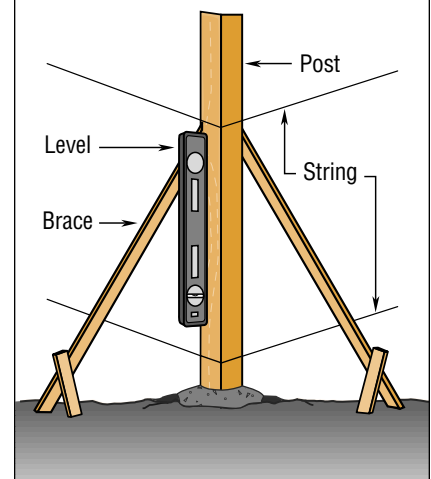

mark and cut the bottom rails and nail them into place.

There are a number of different ways to join the rails to the posts (Fig. 7). Top rails can be mitered, butted, or notched and bolted, while bottom rails can be toe nailed, fastened with a block or metal brace, or inset into the post by cutting a dado or a notch.

Attach fenceboards

This is easily the most satisfying part of the project, because it's here that your fence takes on its final form. The process is also more fun because your most exacting tasks are done. All you need to do is to work out your basic procedure and repeat it until the fence is complete. Time will fly by as you fall into a rhythm of working.

Though there are many different fence styles, they tend to fall into two general categories: nail-on and inset. Neither installation is difficult; however, nail-on is a bit easier and faster, while inset requires somewhat more attention and care in construction and more framing and materials.

Nail-on fencing styles

Nail-on fence styles (Fig. 8) are easier to build because they require fewer steps. Also, you don't need to pre-cut the boards to length unless, of course, you choose to do so. You

Fig. 7: RAIL ATTACHMENTS

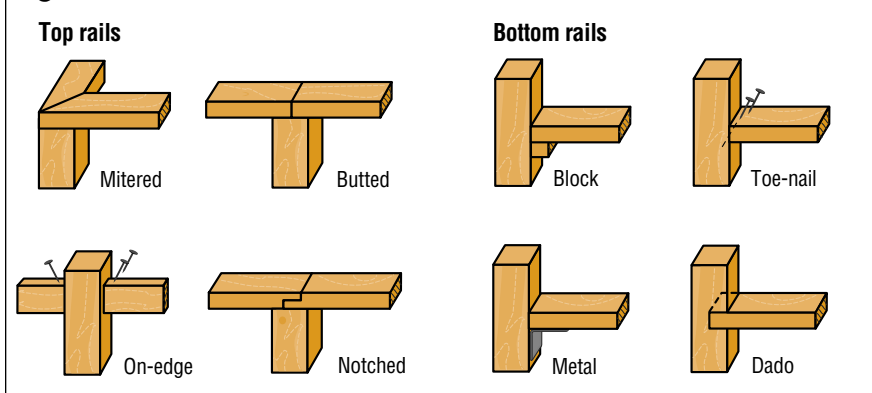

can simply nail the boards at random height and trim them later, using a chalkline to mark your cutting line.

To make sure your fenceboards are raised an even distance from the ground, determine the bottom fence line by tacking your string across several bays at a time, making sure it's level. Then, starting at the end, corner or gate post, use the string as your baseline and begin nailing up your fenceboards. If your fence is designed with spaces between the boards, use a block of wood as a spacer that you can move from one board to the next.

Every few feet it's a good idea to use a level on the vertical edge of the last board you've mounted to make sure it's plumb. If you notice that you're falling out of plumb, you can make minor adjustments over the next few boards until you've gotten rid of the discrepancy.

Trim all the boards at once after attaching them to the rails. Use a chalk line to mark your trim line.

Inset fencing styles

An inset-style fence (Fig. 9) takes more time and additional framing materials, but it results in a fence with clean, graceful lines that will please your neighbors; it's as finished looking on their side as it is on yours.

Start by determining the height and width of several bays. If you discover discrepancies between one bay and another, you may want to measure them all to make sure that boards will be properly cut to fit.

Next, check each bay with a framing square. If anything is out of square, you'll need to make minor adjustments when installing the boards for that bay.

Precut the fence boards to proper length. Now measure and mark the nailing strip positions on each side of the fence and install the outer strips first to give the boards something to rest against as you nail

FIG. 8: NAIL-ON FENCING

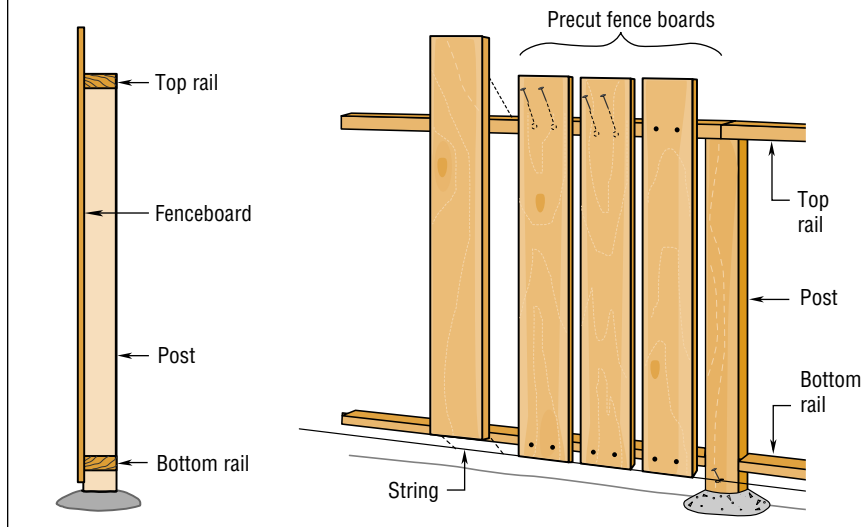

them in place. Toenail the boards to the frame, checking occasionally to make sure that edges are in plumb. Then toenail the other set of nailing strips into position. If your fence design calls for horizontal or diagonal fencing, attach vertical framing strips at the posts. Use the same material as the nailers. You can use any of the various rail attachment techniques when joining the nailer and framing strips at the corners (Fig. 7).

Nails and fasteners

When working with redwood, it's important to use only aluminum alloy, stainless steel, or double *hot-dipped* galvanized fasteners. Inferior hardware, including common iron or steel fasteners or those galvanized by other than the hot-dipped process, is likely to corrode and cause unsightly stains when it comes into contact with moisture. As a guide, select 16-penny common nails for the frame, 8- or 10-penny box nails for the fenceboards, and 6- or 8-penny finish nails for the fine trim.

Fig. 9: INSET FENCING

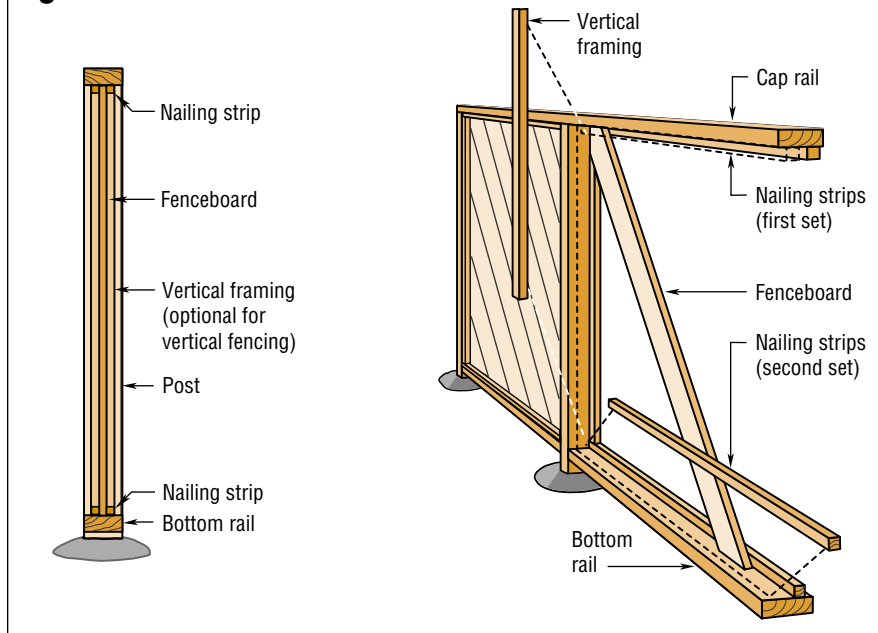

Build and hang the gate

There's something deeply satisfying about a gate that opens easily, swings freely, and closes securely with a reassuring click. Building such a gate requires you to exercise care and craftsmanship in each of the five steps of gate construction: setting the gate posts, building the frame, adding fencing boards, hanging the gate and installing the latch.

Gate posts should be set deeper than your fence line posts—about 1/3 their *total* length—and anchored in concrete. This is necessary because of the need to withstand additional stresses. Posts also must be carefully plumbed so that their inside faces are exactly parallel.

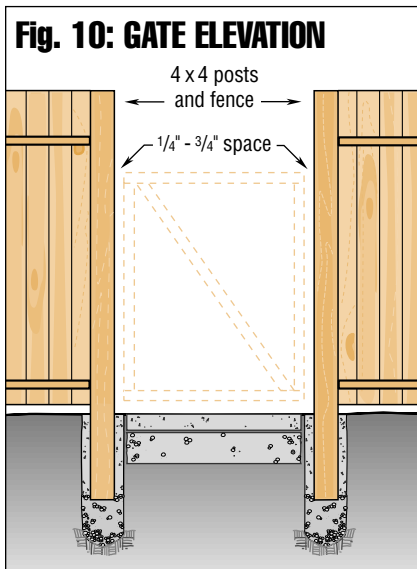

When measuring the opening, make sure to allow for clearances on the hinge and latch sides of the gates (Fig. 10). For gates with standard 2x4 framing and 4x4 posts, leave a 1/2- to 3/4-inch space between the latch post and the gate frame. On the hinge side, it will depend on the hardware you use. About 1/4 inch is usually sufficient.

Once the posts are set, begin assembling the frame (Fig. 11). Cut the pieces to length and assemble them on a flat surface, making

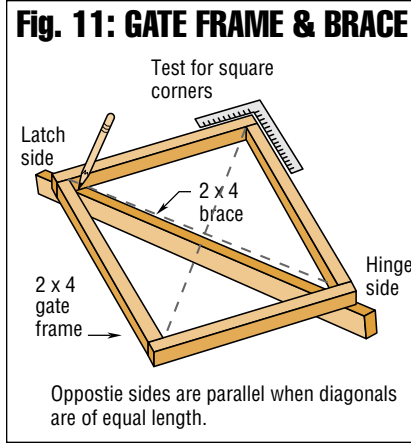

certain that the gate frame is in square. Use a carpenter's square to check the corners and then measure the diagonals. When the diagonals are equal, the sides of your gate are parallel and the frame forms a true rectangle. Use wood screws and a good exterior wood glue instead of nails for added strength.

To measure the brace, lay the frame down on top of the 2x4 bracing member and mark your cut lines. The easiest cut is a single, angled cut so that the brace will run from hinge side bottom to latch side top. Cut the 2x4 just outside your marks so the brace will have a tight fit, and attach the brace to the frame with nails or screws.

Now add the boards, starting from the side where the hinge will go. If the last piece is not flush with the frame edge, either space the boards slightly or plane a little from each board until they fit. Then drill your pilot holes and fasten the hinges to the gate. There are a large variety of hinges and latches to choose from. (Fig. 12 shows the most common.)

At this point you're ready to hang the gate, but before you do anything, you'll want to check the fit by moving the gate in position and trimming any areas that are too tight to provide ample clearance. Now prop the fitted gate into the opening using blocks to support it, or have a helper hold it in position, and mark the hinge and screw hole positions on the post. Once the holes are drilled, replace the gate,

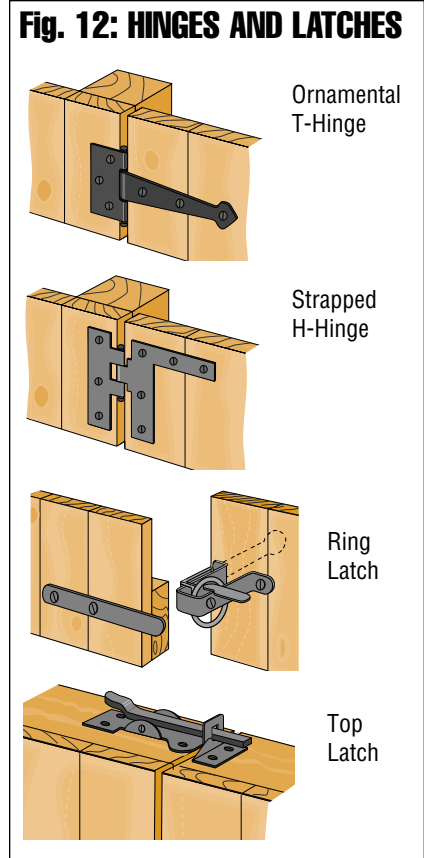

and attach the hinges to the post. Finally, mount the latch assembly on the gate and post, using screws a little longer than usual to help the latch withstand the punishment it will take through years of use.

Finally, it's time to congratulate yourself on a job well done.

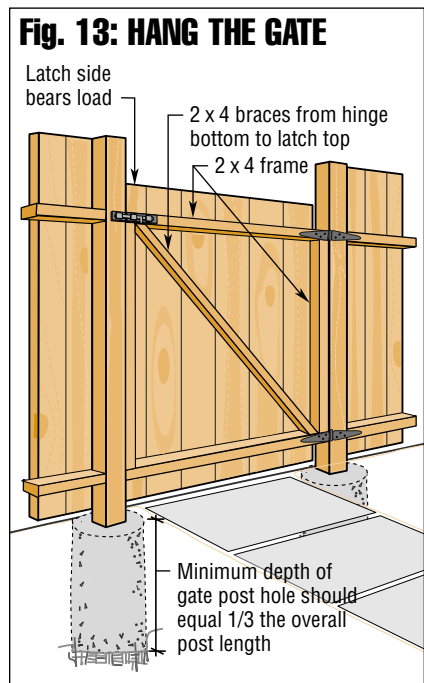

Finishes

No other wood takes and holds finishes better than redwood. California redwood's performance and finish-holding ability make it one of nature's most maintenance-free building materials.

Description	Application	Maintenance
Natural appearance finishes		
Clear Water Repellents with Mildewcide: Clear finishes that modify weathering characteristics and let color and grain show through.	Apply with brush or roller. Use one or two coats according to the manufacturer's directions. For best results, coat sawn ends, backs and edges before nailing in place.	Reapplication may be required after old finish has lost its effectiveness. In humid or harsher climates, reapplication may be required every 12-18 months. Before applying, wood may be restored to its natural color with trisodium phosphate and oxalic acid treatment.
Bleaching or Weathering Stains: Low maintenance, natural appearance with a gray-toned finish.	Apply with brush or roller. Use one or two coats according to manufacturer's directions. Bleaching is aided by sunlight and moisture, so it may speed the process to periodically dampen surfaces with a fine spray from a garden hose.	Bleaching oils and stains provide nearly maintenance-free performance. Reapply finish only if wood begins to darken or bleaching is uneven. One refinish coat should be enough.
Pigmented Stains		
Semitransparent Stains: Penetrating finishes available in a variety of semitransparent colors including several redwood hues. Oil-based stains are recommended.	Apply with brush for best results, next best is a roller. Avoid drips and lap marks. Two coats usually required for new wood—follow manufacturer's directions.	Refinishing may be necessary every 3 to 5 years. Color in pigmented stains may wear away gradually after weathering. Light brushing with a bristle brush will help remove old finish in some spots. One refinish coat is usually enough.
Solid Body Stains: Film forming finishes available in a wide variety of colors. Oil-based stains are recommended.	For best results use a brush. The next best applicator is a roller. Avoid drips and lap marks. Two coats usually required for new wood—follow manufacturer's directions.	Refinishing may be necessary every 3 to 5 years. Color in pigmented stains may wear away gradually after weathering. Light brushing with a bristle brush will help remove old finish in some spots. One refinish coat is usually enough.
Paints		
Paints: Durable, attractive finishes for traditional exteriors. Quality paints are generally worth the extra cost.	Apply with brush for best results, roller is next best applicator. One prime coat and two top coats are recommended for new wood. Back-priming is highly recommended. Use oil- or alkyd-based stain-blocking primer. Acrylic latex top coat is recommended.	Refinishing may be necessary every 7 to 10 years. Paint films that are too thick tend to peel and crack. Sand or scrub with stiff bristle brush. Paint and varnish removers may also be used. If sanding, countersink galvanized nail heads to protect their coating.

Finishes not recommended: varnishes and clear film finishes, oil treatments, "shake and shingle" type paints.