

Windsor Shade Shelter

FREESTANDING SHELTER

This handsome, freestanding redwood shade shelter will provide a cool place to relax in the garden or yard. The shelter can also be built next to your home where it will keep the whole house cooler by shielding windows, walls and sliding glass doors from the sun.

Redwood grades especially suited for this and other outdoor garden projects are Construction Common and Deck Common. Use the all-heart grades, Construction Heart or Deck Heart, where a greater degree of decay resistance is needed.

A simple weekend project, this shelter will shade an area of approximately 8 feet by 12 feet or 96 square feet. The basic plan can be modified by adding more posts, longer beams and additional louvers. If you decide to enlarge this project, keep in mind that the rafters should span no more than 6 feet.

Before beginning any home remodeling project, check with your local building department to learn if a permit is required and to discover any special building codes for your locality.

Use only non-corrosive hardware and fasteners to prevent staining. If you plan to paint your shelter, it will be easier if you prime all edges, ends and sides before constructing the shelter.

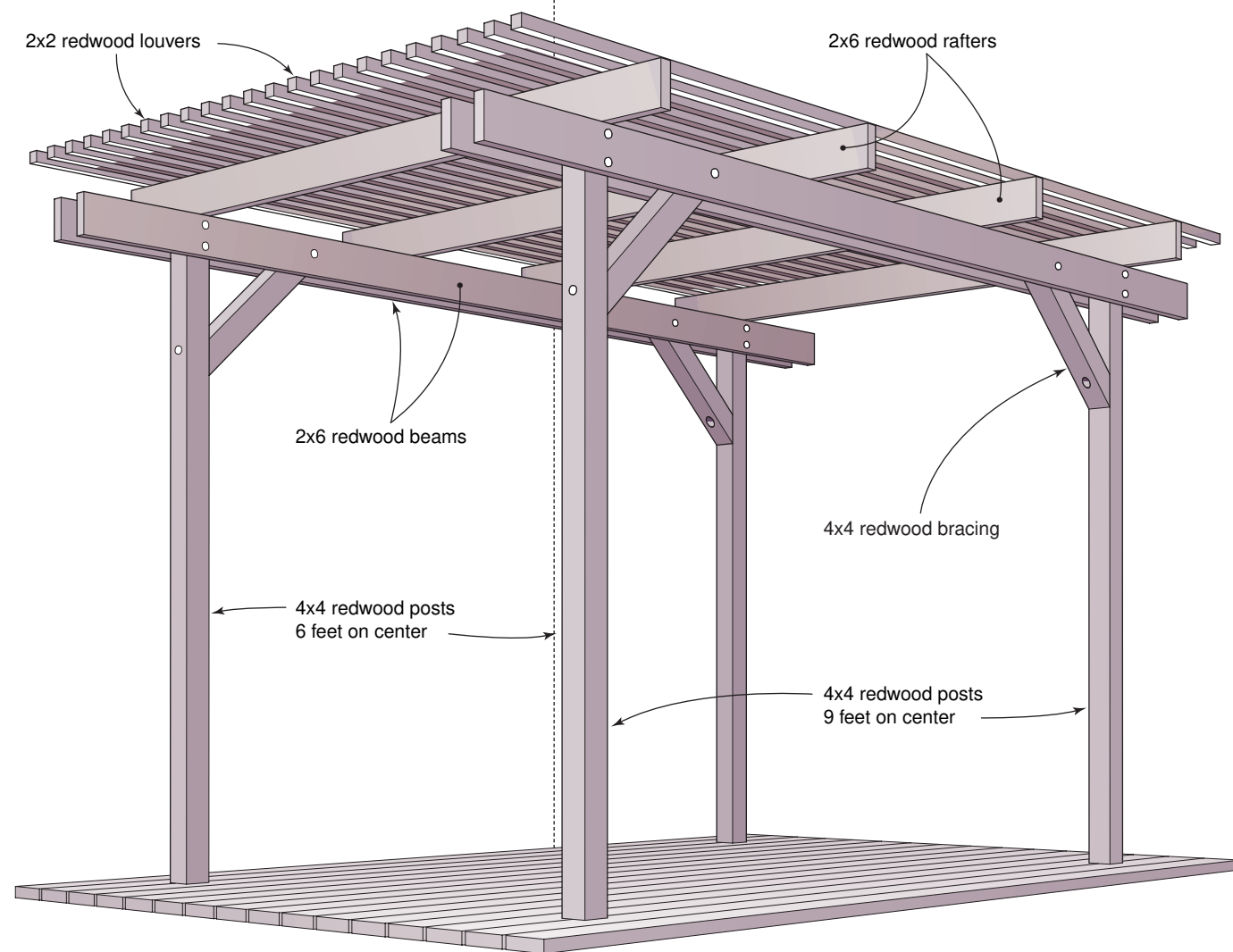

1. Footings Prepare footings for the 4x4 posts which are spaced 6 feet o.c. and 9 feet o.c. The type of footing for posts will vary depending on the deck, patio or type of bare ground the shelter covers. In all cases, the posts should be heartwood grade redwood. Check local building codes for footing requirements in your area. Use quick-setting concrete which hardens in about an hour.

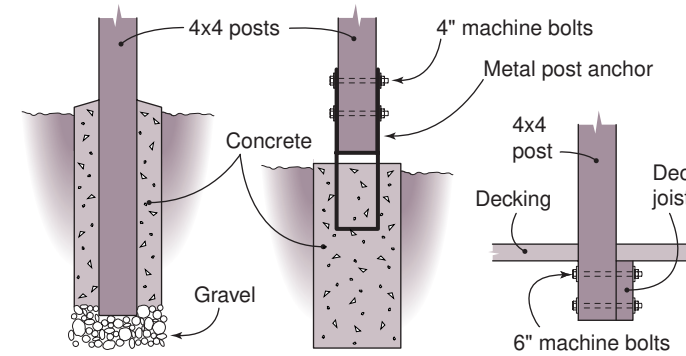

Post embedded in concrete

Post bolted to metal anchors

Post bolted to deck joist

2. Posts Install or attach a 10- to 12-foot-long 4x4 post in each footing. Use a carpenter's level and temporary cross bracing—from the ground to the post—to keep the post plumb. Trim posts to final height if necessary. Posts should measure 8 feet high from the surface of the ground, patio or deck. Remove the temporary bracing once the beams and rafters are installed.

3. Beams Two 12-foot-long 2x6 beams are attached to each set of posts, one on each side and extending 18 inches outward from the center line of the posts. Nail or screw the beams to position them even with the tops of the posts. Drill two 1/2" diameter holes through the double beams and posts. Secure with two 7-inch machine bolts.

4. Braces Cut the remaining 4x4s into four pieces, each 30 inches long and with a 45° angle on each end. Fasten the bottom of each brace with a 6-inch machine bolt and countersink the washer and nut. The top of the brace is sandwiched between the double beams and secured with a 7-inch machine bolt.

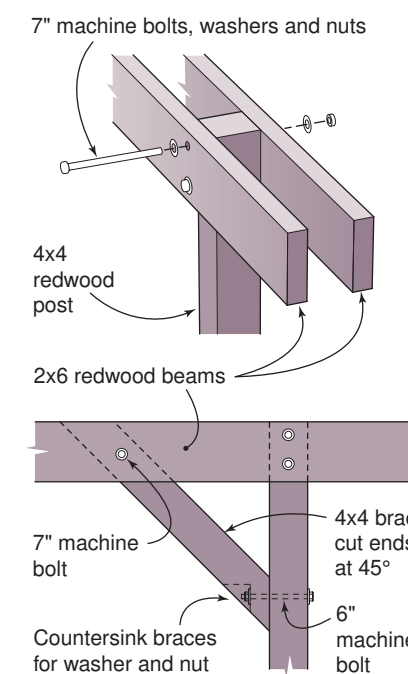

5. Rafters The 8-foot 2x6 rafters start over the posts and are spaced 18 inches o.c. Toenail each rafter with 8d nails on top of the beams extending 12 inches outward front and rear. Secure the rafters with two nails driven through each side of the rafters and into each of the double beams. Screws may also be used. In either case, predrill to prevent splitting. Remove post bracing.

6. Louvers Attach the louvers on top of the rafters with an overhang of 18 inches. Each louver is fastened from above with 8d nails or 2 1/2-inch screws, through predrilled holes, into the rafters below. Check rafter spacing with a ruler and mark each louver for drilling on the ground before installing.

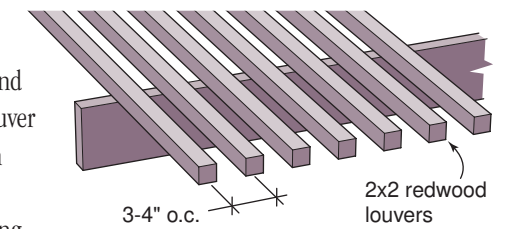

Louver spacing determines the amount of shade the shelter will provide. For moderate filtered sunlight, space louvers 4 inches o.c. If more shade is desired, space louvers 3 inches o.c.—you will require an additional 8 louvers for this spacing.

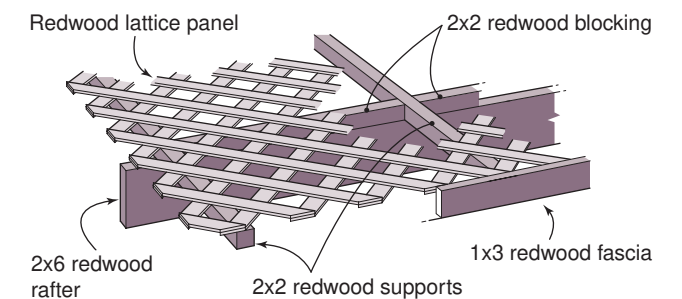

Ready-made lattice As an alternative to louvers, consider using ready-made redwood lattice which will provide moderate filtered sunlight in an interesting pattern. Use 2x2 redwood as supports and blocking. Attach the preassembled 4x8 lattice panels to the 2x2s with 1-inch, non-corrosive fasteners. For a more finished look, frame the lattice all around with 1x3 redwood fascia.

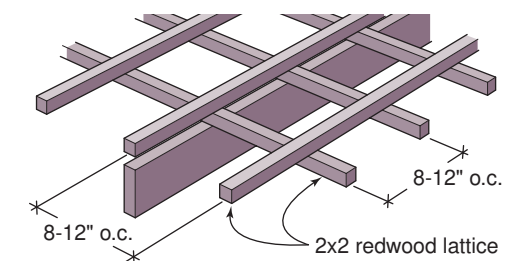

Custom lattice You can design and build your own lattice pattern to meet your shade requirements. Layout the 2x2s for the custom lattice and assemble with non-corrosive fasteners before securing to the rafters.

ATTACHED SHADE SHELTER

The basic design of the redwood shade shelter can be modified so that it may be attached to a home. An 8-foot 2x4 ledger replaces one set of posts and double beam to support the rafters and louvers, and blocking is added between the rafters where they meet the house wall. Use decay-resistant Construction Heart or Deck Heart redwood for these components.

1. Ledger Trim posts to match the height of the ledger attachment. Anchor the ledger to the house framing using 4-inch lag bolts that will pass through the ledger and into the house studs or a window or door header to provide adequate support. When connecting to a header, space bolts no more than 24 inches o.c. Studs are usually spaced 16 inches o.c.

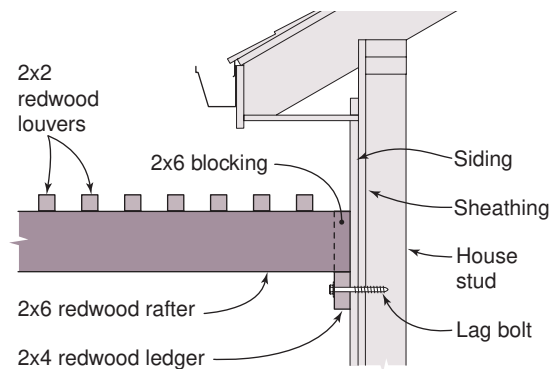

Make sure there is enough room between the ledger and the eaves of the house for the 2x6 rafters and louvers or other shelter material. Use acrylic latex or polyurethane caulking to seal the top joint where the ledger meets the sidewall of the house and to seal the bolts and bolt holes.

2. Rafters and blocking The rafters are positioned on top of the ledger and the beams as in the freestanding version, and are toenailed or screwed in place. Cut to length and nail 2x6 redwood blocking between the rafters at the sidewall of the house. Seal the top edges with caulking to prevent rainwater infiltration.

Custom end details The ends of the double beams, rafters and louvers can be trimmed to provide a custom look. Simple shapes, while easy to create, can add elegance to your project.

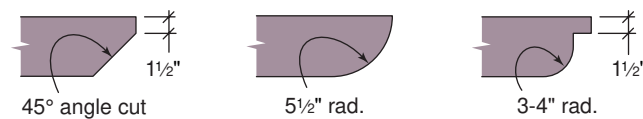

Finishing Finish your shelter with a clear water repellent or stain to enhance the natural beauty of redwood and to extend the life of your project. For finish choices and recommendations, read the Finishes descriptions on the address panel.

Tools you will need: Ruler, tape measure, posthole digger, shovel, wheelbarrow, electric drill, twist drill bits, countersink bit, Phillips head drill bit (for driving deck screws), carpenter's level, hammer, saw and adjustable wrench.

Materials For Freestanding Shelter

	Quantity	Size	Length
Posts	4	4x4	10-12 feet*
Beams	4	2x6	12 feet
Rafters	4	2x6	8 feet
Louvers	23	2x2	12 feet
Braces	4	4x4	3 feet
Machine bolts, washers and nuts	12 sets		1/2x7 inches
	4-12 sets*		1/2x6 inches
Deck screws	2 pounds		2 1/2 inches
Nails	2 pounds	8d	
Concrete and gravel	As needed		

Adjusted Materials For Attached Shade Shelter

	Quantity	Size	Length
Posts	2	4x4	10-12 feet*
Beams	2	2x6	12 feet
Braces	2	4x4	3 feet
Machine bolts, washers and nuts	6 sets		1/2x7 inches
	2-6 sets*		1/2x6 inches
Ledger lag bolts	6-9		3/8x4 inches
Acrylic latex or polyurethane caulking	1 tube		

*Depends upon type of footing used

Contact the California Redwood Association for more great publications containing redwood technical and building information. Call us at 415 382-0662 for a complete literature list or to ask for any of the titles listed here:

Other Construction Tipsheets

Deck Over Concrete
8x10 Deck
Butcherblock Bench
4x4 Planter
Mendocino Bench
Sonoma Picnic Table
Lake Tahoe Gazebo

Also Available

Deck Construction
Deck Grades, Nails and Finishes
Design-A-Deck™ Plans Kit
Fences for All Reasons
Exterior Finishes
Landscape Architecture

Redwood

For beauty and performance, redwood is naturally superior to other woods. That's why it's the first choice for decks, fences and most outdoor projects. Redwood retains its beauty outdoors, shrinks and swells less than other woods and is less likely to warp, split, check or cup. With little or no pitch, redwood is easy to drill, saw and shape. Redwood heartwood has natural durability and resistance to insects and will last longer outdoors than most woods.

Grades

The knotty garden grades of redwood are ideal for outdoor projects. These grades are beautiful, durable and economical.

Construction Heart/Deck Heart is all heartwood and contains knots; used for load-bearing applications near the ground. Deck Heart is graded for strength and is available in 2x4 and 2x6.

Construction Common/Deck Common contains sapwood and knots; used for decking and above-ground uses. Deck Common is graded for strength and is available in 2x4 and 2x6.

Merchantable Heart is all heartwood and contains larger knots than Construction grades; used near the soil.

Merchantable contains sapwood and larger knots; used for fence boards, rails and above-ground uses.

Finishes

Redwood accepts finishes better than most woods. Some heighten redwood's natural beauty, bringing out the color and the grain. Others help the wood harmonize or contrast with surrounding structures. Keep in mind that unfinished redwood will gradually turn soft driftwood gray. Read the labels on all finish products before using.

Clear water repellent finish with mildewcide is recommended to stabilize the color at tan.

Bleaching and weathering stains produce a permanent driftwood gray effect, a good, low-maintenance option.

Semitransparent stains in "redwood" shades tint the wood without hiding the grain.

Solid-color stains or paints should be applied over compatible oil-based primers.

Fasteners

Use only non-corrosive hardware such as aluminum, stainless steel or top quality hot-dipped galvanized screws or nails. Ordinary nails and screws will cause stains.



405 Enfronte Drive, Suite 200
Novato, CA 94949
Telephone 415 382-0662
Toll Free 888 Cal-Redwood
Fax 415 382-8531
www.calredwood.org

BUILD IT WITH
REDWOOD

Windsor Shade Shelter



REDWOOD

Naturally beautiful
Easy to use
Practical and economical
Durable and stable
Resistant to decay and insects