

BUILD IT WITH
REDWOOD

Monterey Potting Center



R E D W O O D

Naturally beautiful

Easy to use

Practical and economical

Durable and stable

Resistant to decay and insects

Whether you are displaying prize bonsai or potting new impatiens, this free-standing redwood potting center creates a peaceful sanctuary and will give years of service.

Construction Common, Deck Common, Merchantable Heart and Merchantable are knotty garden grades of redwood and offer a colorful mix of sapwood and heartwood. Wherever increased decay resistance is needed, use the all-heartwood grades: Construction Heart, Deck Heart or Merchantable Heart.

A good starter do-it-yourself project, the potting center is constructed in simple sections, then fastened together with carriage bolts, washers and nuts for easy set up or knock down. There are plans on the back of this brochure that show an easy-to-build redwood can cradle or a redwood storage bin to complement your potting center.

Measure and cut as you build for best results. Use only non-corrosive nails, bolts and screws to prevent staining. Pre-drill nail holes to minimize splitting near board ends.

1. Leg module On a level surface, lay out two seven-foot 2x4s on edge to start the first leg module (illustration at right, top). Trim three 2x4s to 27³/₈ inches for one leg brace and two shelf supports. Attach the leg brace flush to the bottom of the legs, using two 16d nails or two 3¹/₂-inch deck screws per joint. Attach the shelf supports 16 and 32 inches from the top of the legs. Repeat these steps for constructing the second potting center leg module.

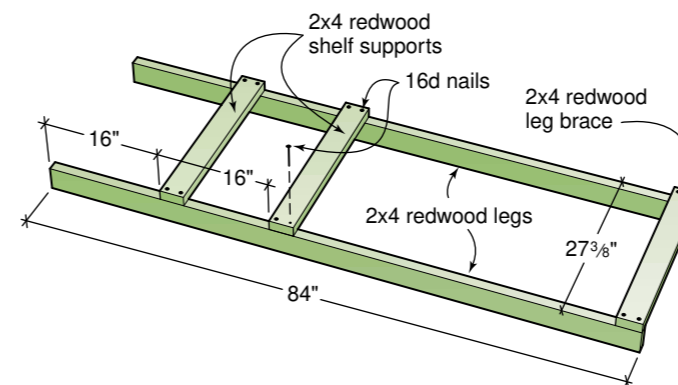

2. Roof The six-foot-long roof calls for fourteen 36-inch 1x4 slats spaced approximately 1¹/₂ inches apart and with a front overhang of 12 inches. This spacing will give plants moderate sun protection. Vary the slat quantity and spacing to suit your shading requirements.

Lay out the 2x4 roof supports on edge and spaced 24 inches apart. Attach the end slats first, flush to the rear support and overhanging the front. Use two 6d nails or two 2-inch deck screws per joint. Position the rest of the roof slats with equal spaces, approximately 1¹/₂ inches, before attaching them.

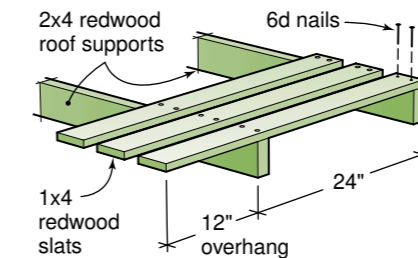

3. Middle shelf With a few minor construction changes, the middle shelf can be built to provide various work or display areas. Here are three options:

Overhang with drainage This variation, shown at left, turns the overhang area into a work surface with water drainage. On six-foot-long frames, lay out thirteen 1x4 slats in the center without spaces and then space three slats at each end 1¹/₄-1¹/₂ inches apart. Attach with 6d nails or 2-inch deck screws.

Simple overhang In this design, the middle shelf is gap-free and overhangs the potting center legs by about 11 inches at each side. Trim twenty 1x4 slats to 24 inches. Begin assembly by laying two six-foot 2x4 middle shelf frames on edge, spaced to 24 inches. Starting at one end, attach all the slats without spaces with nails or screws. Trim the shelf frames to this length.

No overhang For a more compact potting center, construct the middle shelf using just 13 slats with no spacing and no overhang. Follow the directions for the bottom shelf.

4. Bottom shelf Trim two 2x4 shelf frames to 45¹/₂ inches or to match the length of 13 slats nailed side by side with no spaces. Trim thirteen 1x4 slats to 24 inches. Drive two 6d nails or 2-inch deck screws through the slat ends to attach them to the shelf frames. Pre-drill nail holes.

5. Upper shelves Use two or three slats per shelf for the upper shelves, trimmed to 45¹/₂ inches. Trim 1x4 cross braces to match the width of the slats and drive 3d nails or 1¹/₄-inch screws through 1x4 slats into the cross braces. These braces secure the shelving to the structure.

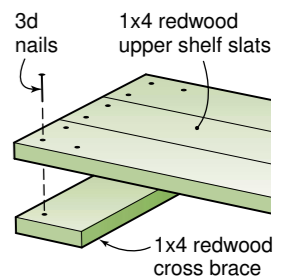

6. Potting center assembly Join the potting center modules together by drilling two 3/8-inch bolt holes through the legs and frames at each junction, starting with the bottom shelf, which rests on the bottom leg brace.

This job will be easier if you temporarily clamp the frames or the roof supports into position while drilling. Measure carefully and check for square. Use non-corrosive 3/8-inch by 3¹/₂-inch carriage bolts with washers and nuts.

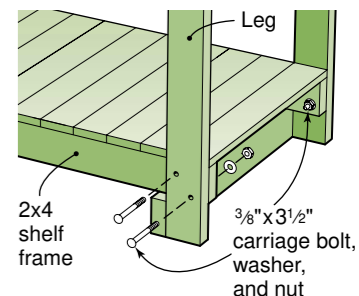

Finishing Lightly sand all cut ends. Apply a clear water repellent or stain containing a mildewcide and UV protector to extend the life of your project. Read important finishes descriptions on the back of this brochure.

Tools you will need Tape measure, carpenter's square, hammer, electric drill with Phillips head drill bit (for driving deck screws), twist drill bits, adjustable wrench or 3/8-inch socket, C-clamps and hand or power saw.

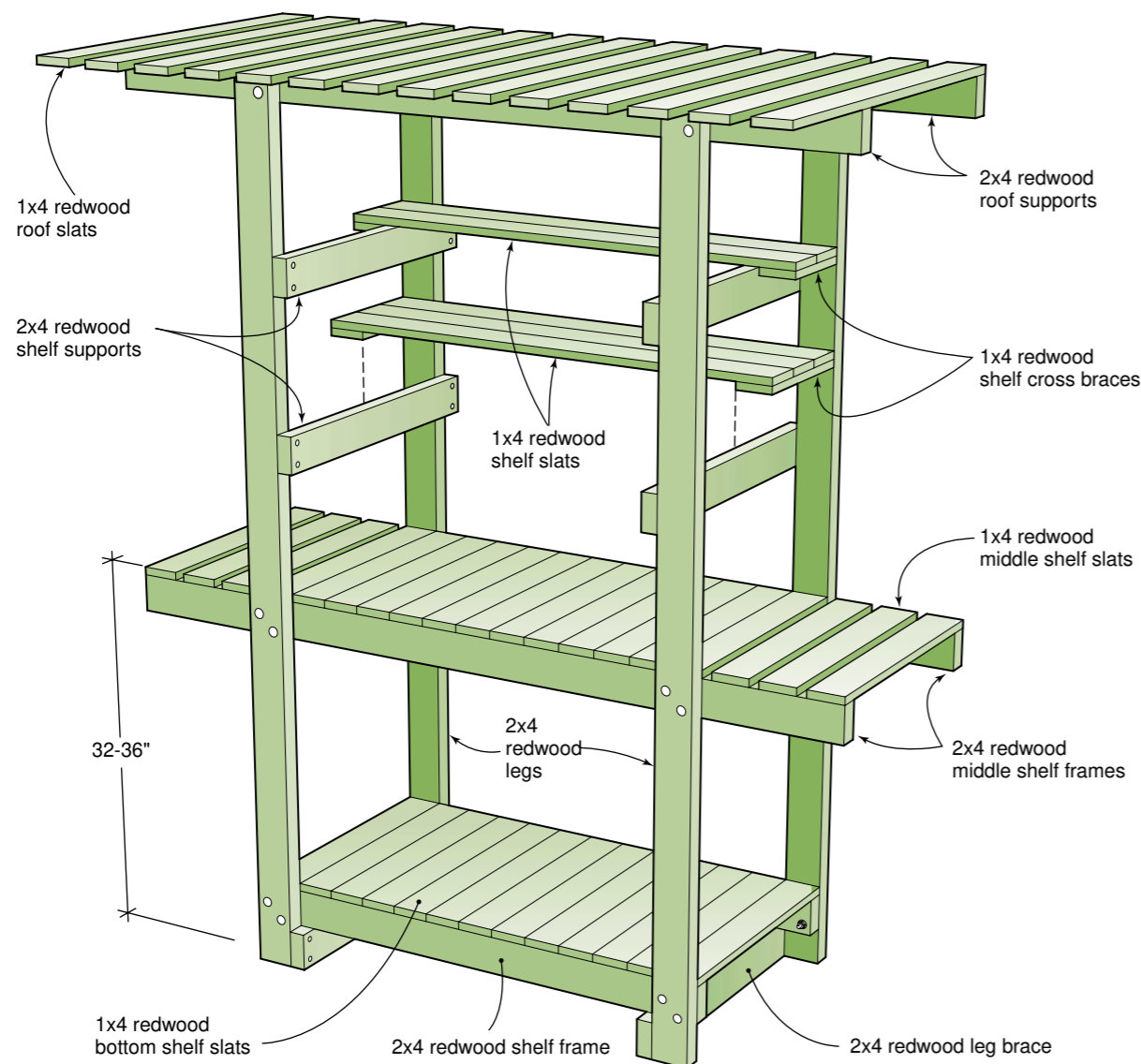

Materials For Potting Center

	Quantity	Size	Length
Legs	4	2x4	7 feet
Leg braces	6	2x4	27 ³ / ₈ inches
Roof supports	2	2x4	6 feet
Roof slats	14	1x4	36 inches
Middle shelf slats	13-20*	1x4	24 inches
Middle shelf frames	2	2x4	45 ¹ / ₂ -72 inches*
Bottom shelf slats	13	1x4	24 inches
Bottom shelf frames	2	2x4	45 ¹ / ₂ inches
Upper shelf slats	4-6*	1x4	45 ¹ / ₂ inches
Upper shelf cross braces	4	1x4	7-10 ¹ / ₂ inches*
Carriage bolts, washers and nuts	24 sets	3/8	3 ¹ / ₂ inches
Nails	1 pound	3d, 6d, 16d	
Deck screws	1 pound		1 ¹ / ₄ , 2 inches

*Depends upon design options chosen

REDWOOD STORAGE BIN

When built, this redwood storage bin will be 19 inches square and 18 inches high and will hold up to 3.5 cubic feet of material. Add casters for greater mobility and line with plastic to minimize water damage.

1. Side panels Use 6d nails or 2-inch deck screws for most attachments. Trim ten each 1x4 boards to 19 inches and 17⁵/₈ inches. Nail the short side 1x4 boards to the four 2x4 vertical cleats trimmed to 15³/₄ inches, starting the boards from the top to allow for a lip at the bottom for the base installation. Trim and install two base cleats to fit between the vertical cleats. Attach the ten 1x4 long side boards to the 2x4 vertical cleats.

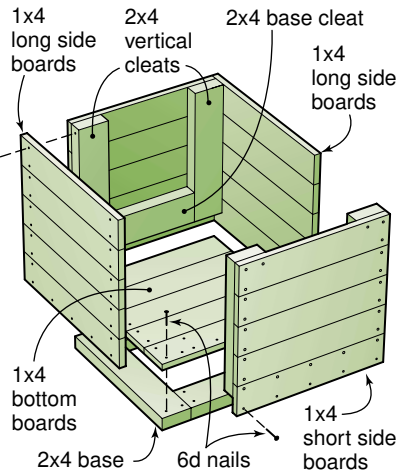

2. Base Tack together 2x4s trimmed to 17⁵/₈ and 10⁵/₈ inches to form the base. Trim 1x4 bottom boards to 17⁵/₈ inches and attach to the 2x4 base with 6d nails. Insert the base inside the bin butting up to the base cleats. Use five nails or screws per side to secure the base. Attach optional casters.

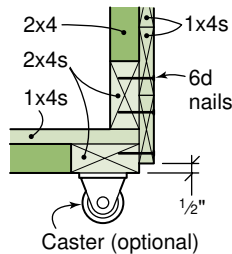

Materials For Redwood Storage Bin

	Quantity	Size	Length
Short side boards	10	1x4	17 ⁵ / ₈ inches
Long side boards	10	1x4	19 inches
Bottom boards	5	1x4	17 ⁵ / ₈ inches
Vertical cleats	4	2x4	15 ³ / ₄ inches
Base cleats	2	2x4	10 ⁵ / ₈ inches
Base	2 each	2x4	10 ⁵ / ₈ , 17 ⁵ / ₈ inches
Nails or screws			6d nails or 2-inch deck screws

Materials For Redwood Can Cradle

	Quantity	Size	Length
Front, bottom and rear frames	3	2x4	17 inches
Side frames	2	2x4	18 inches
Posts	2	2x4	10 ¹ / ₂ inches
Front boards	3	1x4	20 inches
Nails			6d, 10d nails
Deck screws			3 inches

REDWOOD CAN CRADLE

This redwood can cradle will hold a 30-gallon can at an accessible angle for removing soil or fertilizer.

1. Frames and posts Trim the rear and bottom frames to 15¹/₄ inches. Cut 1¹/₂x2-inch notches in the ends of the front bottom frame. Trim 2x4 redwood posts to 10¹/₂ inches and notch one end to 1¹/₂x3 inches. Attach the posts to the front frame at the notch with 3-inch deck screws. Use 10d nails to fasten the 2x4 rear frame to the bottom frame. Trim side frames to 18 inches and cut the ends on one side to a 45° by 1/2-inch bevel. Use 3-inch deck screws to attach the side frames to the assembled front frames at their notches. The rear frame attaches to the side frame 1/2 inch from the bottom edge (see detail illustration), also with 3-inch screws.

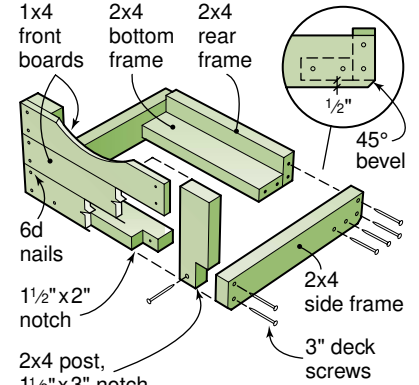

2. Front boards

Trim three 1x4 redwood boards to 20 inches. Mark the center line of the top board and using a cardboard template, transfer and cut a 9-inch radius cut to a depth of 2 inches. Lightly sand the cut. Attach the front 1x4 redwood boards with two 6d nails per board end, remembering to predrill nail holes.

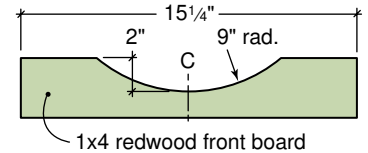

Contact the California Redwood Association for more great publications containing redwood technical and building information. Call us at 415 382-0662 for a complete literature list or to ask for any of the titles listed here:

Other Construction Tipsheets

Deck Over Concrete
8x10 Deck
Butcherblock Bench
4x4 Planter
Sonoma Picnic Table
Lake Tahoe Gazebo
Petaluma Planters
Windsor Shade Shelter
Mendocino Bench
Calistoga Spa Surround

Also Available

Deck Construction
Deck Grades, Nails and Finishes
Fences for All Reasons
Exterior Finishes
Landscape Architecture

Redwood

For beauty and performance, redwood is naturally superior to other woods. That's why it's the first choice for decks, fences and most outdoor projects. Redwood retains its beauty outdoors, shrinks and swells less than other woods and is less likely to warp, split, check or cup. With little or no pitch, redwood is easy to drill, saw and shape. Redwood heartwood has natural durability and resistance to insects and will last longer outdoors than most woods.

Grades

The knotty garden grades of redwood are ideal for outdoor projects. These grades are beautiful, durable and economical.

Construction Heart/Deck Heart is all heartwood and contains knots; used for load-bearing applications near the ground. Deck Heart is graded for strength and is available in 2x4 and 2x6.

Construction Common/Deck Common contains sapwood and knots; used for decking and above-ground uses. Deck Common is graded for strength and is available in 2x4 and 2x6.

Merchantable Heart is all heartwood and contains larger knots than Construction grades; used near the soil.

Merchantable contains sapwood and larger knots; used for fence boards, rails and above-ground uses.

Finishes

Redwood accepts finishes better than most woods. Some heighten redwood's natural beauty, bringing out the color and the grain. Others help the wood harmonize or contrast with surrounding structures. Keep in mind that unfinished redwood will gradually turn soft driftwood gray. Read the labels on all finish products before using.

Clear water repellent finish with mildewcide is recommended to stabilize the color at tan.

Bleaching and weathering stains produce a permanent driftwood gray effect, a good, low-maintenance option.

Semitransparent stains in "redwood" shades tint the wood without hiding the grain.

Solid-color stains or paints should be applied over compatible oil-based primers.

Fasteners

Use only non-corrosive hardware such as aluminum, stainless steel or top quality hot-dipped galvanized screws or nails. Ordinary nails and screws will cause stains.



405 Enfrente Drive, Suite 200
Novato, CA 94949
Telephone 415 382-0662
Toll Free 888 Cal-Redwood
Fax 415 382-8531
www.calredwood.org